



blejzyk.pl RC MODELS

producent modeli szybowców i motoszybowców RC

FEN - Building Guide

Welcome and congratulations on your purchase. We hope that our product will provide you with many enjoyable flying hours as well as being a pleasure to build.

Please treat this manual as a guide only. Your own modifications to the building process are welcome.

We believe that the following steps are essential in achieving a success with the model:

- Before commencing with the assembly read the entire manual.
- Trial fit all parts.
- All glued parts (and their mating components) should be sanded using ≈ 240 sandpaper. This applies mainly to all plywood reinforcements in fuselage, tow hook and inner nose cone.
- Accurately and neatly finished models, usually fly better.

Kit Contents

Fibreglass Fuselage, Inner Nose Cone, Sheath nose
Pre-hinged V-tail Stabiliser & Mount
Sheeted and Sanded Wing Panels
Wing Hardwood blocks (2)
Ballast Compartment Plywood
Wing Plate Plywoods (2 pieces)
Tail Reinforcement Plywood
Tail M3 Nylon Bolts & Brass Nuts (2)
Wing M4 Nylon Bolts & Nuts (2)
Tow Hook
V-Tail Control Horns (2)
Fibreglass Cloth Strips

Wings

Place the wing centre sections together and mark the position of the hardwood blocks on the skin, as per the general arrangement drawing. Remove the foam in each wing to the depth of half width of the hardwood blocks. Shape the blocks to achieve a loose fit. Using a blunt tool (a piece of hardwood) push in the foam to a depth of approximately 1mm around the perimeter of the wing root. This operation will allow a stronger wing joint.

Lay down a piece of wax paper to protect your building board and cover the wing for 50mm or so to protect the veneer from any epoxy overspill. Smear 1hour epoxy inside the holes and the entire wing root area of the centre wing section. Insert the hardwood blocks and make sure that the space between the hardwood blocks and the top and bottom veneer is filled up with the epoxy. While holding one wing half flat on the building board, apply 36mm dihedral at the tip of the other wing half. The wing panels have been already sanded to the correct dihedral. Make sure that both wing halves match each other. Masking tape can be used to hold the wing halves together. Allow the epoxy to cure completely.

The outer wing panels should now be glued to the centre wing sections. As before, push in the foam to a depth of approximately 1mm around the perimeter of the both wing roots, and cover the wing root for 50mm or so to protect the veneer from any epoxy overspill. Smear 5min epoxy and apply 55 mm dihedral at the tip of the outer wing panel. The centre wing section should be held flat on the building board during this operation. Allow the epoxy to cure completely.

Apply the provided strips of fibreglass cloth at the top and bottom of all dihedral breaks. Use slow curing epoxy (1 hour) in order to achieve a good penetration and strength.

Drill two ϕ 4mm holes through the hardwood blocks for the wing bolts. The holes should be perpendicular to the top surface of the wing, see the general arrangement drawing.

At this stage the wing should be sanded lightly with a fine sandpaper and sealed with a clear varnish. Any type of a suitable, lightweight varnish can be used to protect the wing and tail from moisture and aging. Although an epoxy was used to glue the veneer to the wing cores, care should be taken when using non-water based varnishes so as not to destroy the wing foam.

TAIL

The edges of the tail have been already pre- sanded to a correct angle. Join all three parts together using a 5min epoxy. We recommend using cardboard templates to hold the V-tail while the glue cures. Reinforce the joints with pieces of the supplied fibreglass cloth.

The tail can be permanently glued to the fuselage or alternatively attached using M3 bolts. The former method is quick and easy but can be problematic during transport. Details of the bolted version are provided in the following section "**Fuselage**"

Install the supplied control horns.

FUSELAGE

Wing position on top of the fuselage:

- HN1033 profile: as per drawing
- S6063 profile: move the wing forward by approximately the thickness of the leading edge

Cut a hole in the wing seating so that a receiver can be inserted. Glue the wing seating plates using 5min epoxy. The wing seating plates can be shaped to a slight V angle to accommodate the wing dihedral.

Using the wing holes as guides, drill two ϕ 4mm holes in the fuselage (and wing seating plates). Double sided tape can be used to hold the wing during this operation. Take off the wing and re-bore the fuselage holes to ϕ 5.5mm and insert the provided nuts. Place the wing

on top of the fuselage again and trial fit the wing bolts. It is important for the nuts to fit tightly inside the fuselage holes up to the collar. Lock the nuts in place using CA glue.

Should you have opted for a removable tail, glue the plywood reinforcement to the tail seat (inside the fuselage). Drill 2 x $\phi 3\text{mm}$ holes in the V-tail mount. Place the tail on top of the fuselage and drill 2 x $\phi 3\text{mm}$ holes using the tail holes as guides. Make sure that the tail is correctly aligned. Lock the brass nuts in place using CA glue.

If required, install a tow hook using 2-3 layers of fibreglass as reinforcement.

Bowden cables can be glued at 2-3 places inside the fuselage using CA or epoxy glues. Alternatively, they can be glued to a 3mm piece of balsa shaped to conform to the inside contour of the fuselage. The entire assembly is then glued inside the fuselage.

Cut a hole for the receiver battery in the inner nose part. Insert through this hole a $\phi 26\text{mm}$ plate cut from the supplied plywood. This plate will act as a closure for the ballast compartment. Drill a hole on top of the ballast compartment so that small pieces of lead can be inserted.

Cut holes for the servos. It is recommended to reinforce with plywood the areas where the servos will be bolted down. Drill holes for the bowden cables.

Drill 4 x $\phi 4\text{mm}$ holes around the circumference of the inner nose cone, 7 mm from the edge. These holes will allow excess glue to drain away as well as provide a better bond. Insert the inner nose cone deeply into the sheath nose. Trial fit it into the fuselage. Light sanding may sometimes be required in order to obtain a good fit inside the fuselage. Sand the outside of the inner nose cone and the inside of the fuselage (the areas to be glued together) with a fine sandpaper. Smear the inside of the fuselage with 5min epoxy and push in the sheath nose/inner nose assembly into the fuselage. Carefully align the sheath nose with the fuselage and tape the joint line. Use a liberal amount of epoxy for this operation but be careful not to glue the sheath nose to the inner cone.

EQUIPMENT

Micro servos should be used in the fuselage.

Insert 270-350mAh battery into the fuselage.

The receiver is positioned behind the servos and the aerial can be routed inside the fuselage.

Recommended Control Throws:

Elevator – 9mm up/down

Rudder – 9 left/right

These are only recommended initial throws and can be changed to suit individual flying styles.



blejzyk.pl RC MODELS

producent modeli szybowców i motoszybowców RC



blejzyk.pl RC MODELS

producent modeli szybowców i motoszybowców RC

CG POSITION

For the first flights we recommend that the model should be balanced 74mm from the leading edge, measuring in the CL of the fuselage. After the first flight the CG position and wing incidence angle can be adjusted to suit individual flying styles.

ELECTRIC VERSION

However, any suitable motor and reduction gear can be used. Cut the nose of the electric fuselage at the diameter of the spinner. The fuselage CL is already set $\approx 2^\circ$ down, so no extra down thrust angle is required, see Figure 1. Just set the motor mount parallel to the nose closing bulkhead. The motor mount can be made from a plywood-epoxy board laminate, each approximately 1.6 mm thick. Cut the air vent holes and drill holes for the motor fixing screws. Glue the motor mount using epoxy and carbon fibre tows. Trim the inner nose cone to suit the motor/reduction gear shape.

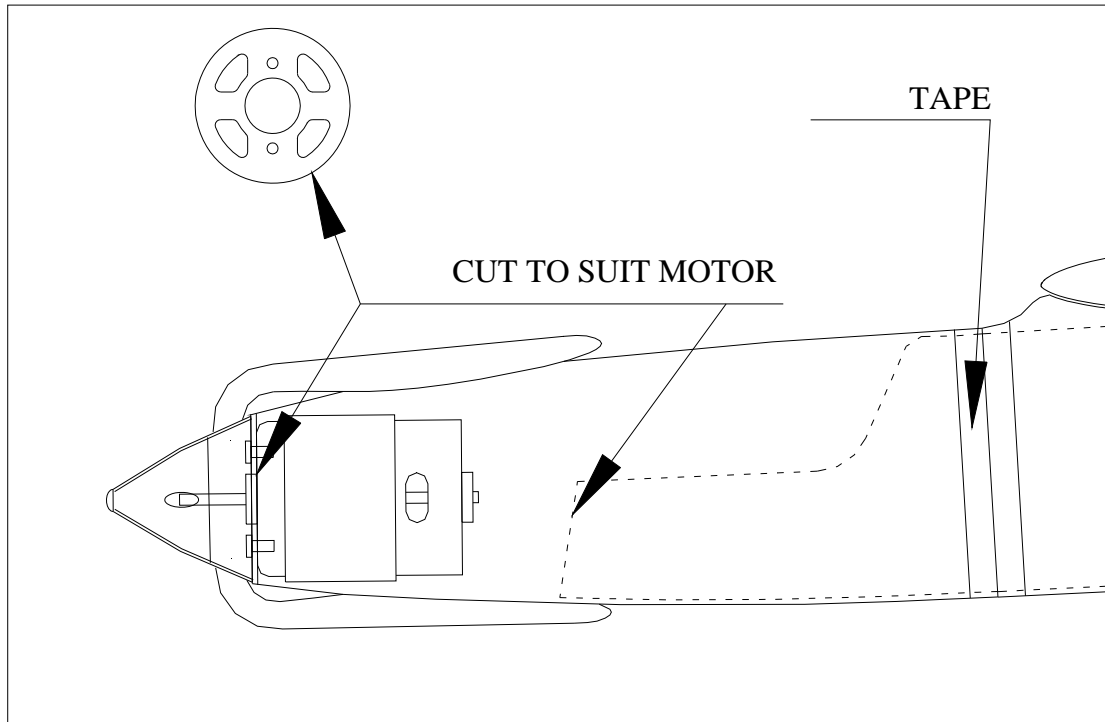

Figure 1