



blejzyk.pl RC MODELS

producent modeli szybowców i motoszybowców RC

FIRST 2M - Building Guide

Welcome and congratulations on your purchase. We hope that our product will provide you with many enjoyable flying hours as well as being a pleasure to build.

Please treat this manual as a guide only. Your own modifications to the building process are welcome.

We believe that the following steps are essential in achieving success with the model:

- Before commencing with the assembly read the entire manual.
- Trial fit all parts.
- All glued parts (and their mating components) should be sanded using ≈ 240 sandpaper. This applies mainly to all plywood reinforcements in fuselage, tow hook and inner nose cone.
- Accurately and neatly finished models, usually fly better.

Kit Contents

Fibreglass Fuselage, Inner Nose Cone, Sheath nose
Pre-hinged V-tail Stabiliser & Mount
Sheeted and Sanded Wing Halves
Wing Hardwood blocks (4)
Closing Rib Plywood
Ballast Compartment Plywood
Wing Plate Plywoods (2 pieces)
Tail Reinforcement Plywood
Tail M4 Nylon Bolts & Nuts (2)
Wing M4 Nylon Bolts & Nuts (4)
Wing Joiner
Auxiliary Wing Joiners (2)
Tow Hook
Aileron Control Horns (2)
V-Tail Control Horns (2)
Fibreglass Cloth Strips

Wings

The wing joining system for this model consists of a steel joiner bar and a brass joiner box. The steel joiner bar is permanently glued into one wing, while the brass joiner box is permanently glued into the other wing, see Figure 1.

Blank-off one end of the brass box with a flat piece of fibreglass soaked in resin. When completely cured and dry, insert the steel joiner into the brass box and trial fit them into the wing spars. The brass box should be fully inserted into one wing while the steel joiner should be half inserted into the brass box, see Figure 1. Position one wing half flat on a building board and apply 50mm dihedral at the tip of the other half. The wings have been already sanded to the correct dihedral. Pieces of balsa, books etc can be used to hold the required dihedral. It might be necessary to file the bottom of the steel joiner in order to achieve the required dihedral. Separate the wings and remove the steel bar and brass box. Sand the entire outside surface of the brass box and one half of the steel joiner (the one outside the brass box).

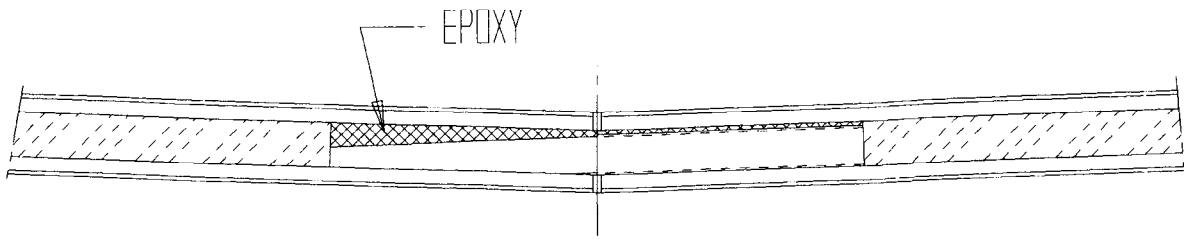

Figure 1

Lay down a piece of wax paper to protect your building board and cover the wing root for 50mm or so to protect the veneer from any epoxy overspill. Smear a small amount of 5min epoxy at the bottom of the assembled brass box and steel joiner and insert them into the wings. Using masking tape hold the two wing halves together (with 50mm dihedral), making sure that both halves match each other. Be careful not to glue the wings together. Allow the epoxy to cure.

Once cured, gently move both wing halves apart. You now need to fill the voids in the wing spars with epoxy. Use slow curing epoxy (minimum 1 hour) in order to achieve a good penetration and strength. Position the wing halves vertically and fill the voids with epoxy using a syringe. Allow the epoxy to cure completely.

Assemble the wing halves together and mark the position of the hardwood blocks on the skin, as per the general arrangement drawing. Remove the foam to the depth of the hardwood blocks and shape the blocks to achieve a loose fit. Cut the wing closing ribs from the supplied ply. The ribs should be slightly bigger than the actual root wing profile. Cut slots for the wing joiner and servo leads in both ribs.

Using a blunt tool (a piece of hardwood) push in the foam to a depth of approximately 1mm around the perimeter of the wing root. This operation will allow a stronger joint with the closing ribs.

Smear a slow curing epoxy (1 hour) with microballoons inside the holes and insert the hardwood blocks. Make sure that the space between the hardwood blocks and the top and bottom veneer is filled up with the epoxy. Apply the glue to the entire wing root area and glue-in the closing ribs. Use masking tape to hold the ribs. Allow the epoxy to cure.

Sand the closing ribs flush with the wing profile.

Drill two x ϕ 4mm holes through the hardwood blocks in each wing half for the wing bolts. The holes should be perpendicular to the top surface of the wing, see the general arrangement drawing. Drill two horizontal ϕ 2mm holes in the hardwood blocks for the auxiliary wing joiners. Vertical and horizontal holes should be staggered. Trial fit the auxiliary joiners. Adjustment can be made by reboring the holes, but only those in which joiners will be glued in. Epoxy the auxiliary joiners into the wing halves.

Cut out the ailerons with a sharp hobby knife. With a blunt tool push in the foam on aileron and wing sides to a depth of 2-3 mm. Fill the voids with a mixture of 10 minutes epoxy and microballoons. Allow the epoxy to cure completely. Sand the sides flush. Sand the bottom front edge of the aileron so that it can deflect down.

The position of the wing servos is marked on the wings. Cut out the veneer and foam so that a servo fits very snugly inside the servo hole.

At this stage the wing should be sanded lightly with a fine sandpaper and sealed with a clear varnish. Any type of a suitable, lightweight varnish can be used to protect the wing and tail from moisture and aging. Although an epoxy was used to glue the veneer to the wing cores, care should be taken when using non-water based varnishes so as not to destroy the wing foam.

Ailerons can be attached with a clear tape. Start at the top surface and then turn the aileron flat on the top of the wing. Tape the bottom surface.

Install the aileron horn directly in line with the servo arm.

TAIL

The edges of the tail have been already pre-sanded to a correct angle. Join all three parts together using a 5min epoxy. We recommend using cardboard templates to hold the V-tail while the glue cures. Reinforce the joints with pieces of the supplied fibreglass cloth.

The tail can be permanently glued to the fuselage or alternatively attached using M4 bolts. The former method is quick and easy but can be problematic during transport. Details of the bolted version are provided in the following section "**Fuselage**"

FUSELAGE

Cut a hole in the wing seating so that a receiver can be inserted. Glue the wing seating plates using 5min epoxy. The wing seating plates can be shaped to a slight V angle to accommodate the wing dihedral. Assemble the wing halves and drill 4 x ϕ 4mm holes in the fuselage (and wing seating plates) using the wing holes as guides. Double sided tape can be used to hold the wing during this operation. Take off the wing and rebore the fuselage holes to ϕ 5.5mm and insert the provided nuts. Place the wing on top of the fuselage again and trial fit the wing bolts. It is important for the nuts to fit tightly inside the fuselage holes up to the collar. Lock the nuts in place using CA glue.

Should you have opted for a removable tail, glue a plywood reinforcement to the tail seat (inside the fuselage). Drill 2 ϕ 4mm holes in the V-tail mount. Place the tail on top of the fuselage and drill ϕ 4mm holes using the tail holes as guides. Make sure that the tail is correctly aligned. Rebore the fuselage holes to ϕ 5.5mm and insert the provided nuts. Lock the nuts in place using CA glue. Install the supplied control horns.

If required, install a tow hook using 2-3 layers of fibreglass as reinforcement.

Bowden cables can be glued at 2-3 places inside the fuselage using CA or epoxy glues. Alternatively, they can be glued to a 3mm piece of balsa shaped to conform to the inside contour of the fuselage. The entire assembly is then glued inside the fuselage.

Cut a hole for the receiver battery in the inner nose part. Insert through this hole a ϕ 36mm plate cut from the supplied plywood. This plate will act as a closure for the ballast compartment. Drill a hole on top of the ballast compartment so that small pieces of lead can be inserted.

Cut holes for the servos. It is recommended to reinforce with plywood the areas where the servos will be bolted down. Drill holes for the bowden cables.

Drill 4 x ϕ 4mm holes around the circumference of the inner nose cone, 7 mm from the edge. These holes will allow excess glue to drain away as well as provide a better bond. Insert the inner nose cone deeply into the sheath nose. Trial fit it into the fuselage. Light sanding may sometimes be required in order to obtain a good fit inside the fuselage. Sand the outside of the inner nose cone and the inside of the fuselage (the areas to be glued together) with a fine sandpaper. Smear the inside of the fuselage with 5min epoxy and push in the sheath nose/inner nose assembly into the fuselage. Carefully align the sheath nose with the fuselage and tape the joint line. Use a liberal amount of epoxy for this operation but be careful not to glue the sheath nose to the inner cone.

EQUIPMENT

This model can be flown with a rudder/elevator/aileron or just elevator/aileron.

Standard size or smaller servos can be used in the fuselage. Wing servos can be installed using a small amount of silicon sealer. Before gluing the servos into the wings, wrap them with electrical insulating tape.

Insert a 350-800mAh battery into the fuselage.

The receiver is positioned behind the servos and the aerial can be routed inside the fuselage.

Recommended Control Throws:

Elevator – 9mm up/down

Aileron – 10 up, 6 down

Rudder – 9 left/right

These are only recommended initial throws and can be changed to suit individual flying styles.

CG POSITION

For the first flights we recommend that the model should be balanced 85mm from the leading edge, measuring in the CL of the fuselage. After the first flight the CG position and wing incidence angle can be adjusted to suit individual flying styles.

ELECTRIC VERSION

However, any suitable motor and reduction gear can be used. Cut the nose of the electric fuselage at the diameter of the spinner. The fuselage CL is already set $\approx 2^\circ$ down, so no extra down thrust angle is required, see Figure 2. Just set the motor mount parallel to the nose closing bulkhead. The motor mount can be made from a plywood-epoxy board laminate, each approximately 1.6 mm thick. Cut the air vent holes and drill holes for the motor fixing screws. Glue the motor mount using epoxy and carbon fibre tows. Trim the inner nose cone to suit the motor/reduction gear shape.

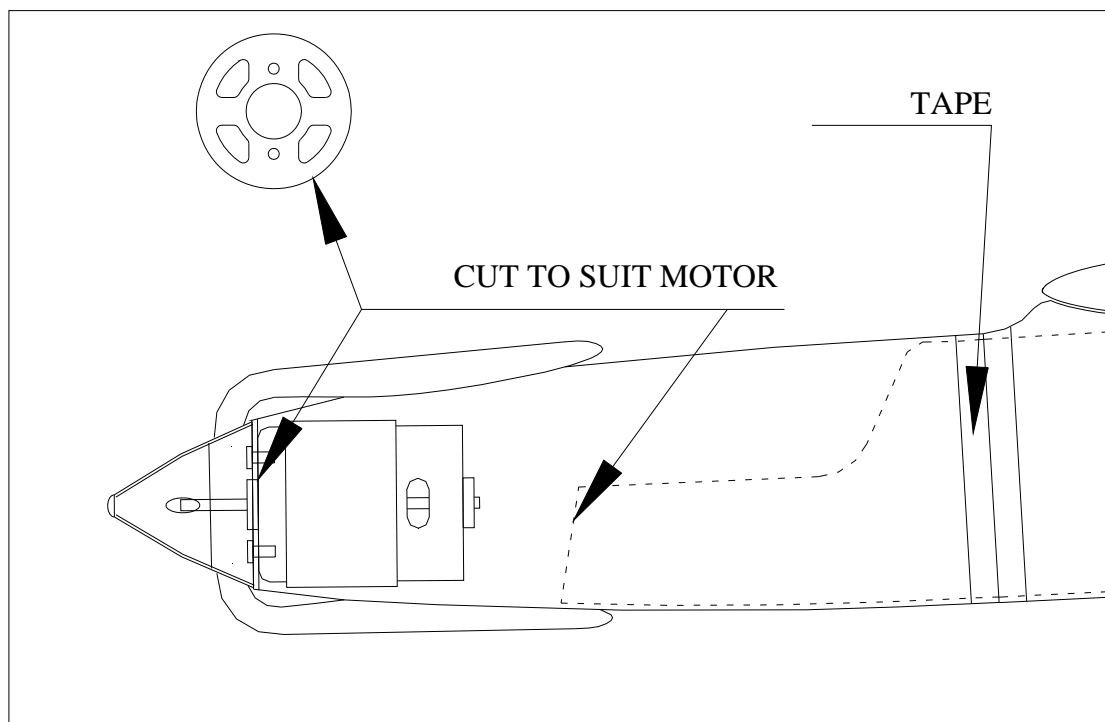

Figure 2